



**Gasmaster Industries  
Bldg #8, 15050 54A Ave.  
Surrey, British Columbia  
Canada V3S 5X7**

**GMI 8M  
8,000,000 Btu/hr Input  
Gas-Fired Stainless Steel Boilers**

**INSTALLATION, OPERATION AND  
MAINTENANCE MANUAL**

Serial Number: XXX.xx  
Generic

# List of Contents

Title	Page
<b>GMI 8M SPECIFICATIONS AND DIMENSIONS</b>	3
<b>SECTION 1: INTRODUCTIONS</b>	
1.1 Boiler Description	5
1.2 Control System	6
1.3 Safety Features	6
1.4 Gas Line	7
1.5 Gas Manifold and Control Assembly	9
1.6 Code Compliance	9
1.7 Freeze Protection	10
1.8 Water Treatment	10
<b>SECTION 2: INSTALLATION</b>	
2.1 Boiler Package	12
2.2 Location	13
2.3 Relief Valve	14
2.4 Water Connection	14
2.5 Condensate Line	14
2.6 Gas Line Connection	15
2.7 Vent Connection	15
2.8 General Instruction	18
<b>SECTION 3: OPERATION</b>	
3.1 Sequence of Operation	21
3.1.1 Safety Loop	21
A: Components	21
B: Sequence of Events	22
3.1.2 Pre-Purge	22
3.1.3 Main Flame	23
3.1.4 Operation	23
3.2 Pre Commissioning	24
3.3 Commissioning	26
3.4 General Instruction	28
<b>SECTION 4: MAINTENANCE</b>	
4.1 Service Hint	30
Troubleshooting	31
<b>ATTACHMENTS:</b>	
<b>1- Wiring diagram</b>	33
<b>2- Start-up report</b>	34

## GMI 8M SPECIFICATIONS AND DIMENSIONS

Input	Btu/h	8000,000
Fuel		Natural Gas
Electrical Rating	V/PH/Hz/A	208,230,460,575 three phase, 60Hz, less than 12 Amps.
Heating surface	Ft <sup>2</sup>	991.57
Boiler Shell Dimensions		
- Width	Inches	68"±0.25"
- Depth	Inches	58.75"±0.25"
- Height	Inches	68"±0.25"
-		
Overall Dimensions		
- Width	Inches	69"±0.25"
- Depth	Inches	98"±0.25"
- Height	Inches	88.5"±0.25"
Shipping Weight	Lbs	5200
Supply Connections	Inches	4" - Stainless Steel Flange, ANSI 150 lbs, QTY=2
Return Connections	Inches	4" - Stainless Steel Flange, ANSI 150 lbs, QTY=1
Water content	USG	165
Gas connection	Inches	2.5"-4" NPTF
Gas inlet pressure	PSI	1- 5
Flue connection	Inches	24
Flue duct material		Stainless Steel (air tight, corrosion resistant)
Air supply connection	Inches	N/A
Maximum working pressure	psig	160
Maximum working temperature	Degrees F	210
Minimum inlet water temperature		Any temperature above freezing
Minimum water flow rate	USG/min	80
Minimum service clearance	Inches	Top 40, Front 40, Back 10, Floor 0
Minimum clearances to combustibles	Inches	Top 40, Front 40, Back 24, Sides 24, Flue 6, Floor non-combustible

**SECTION 1:**  
**INTRODUCTION**

## 1.1 Boiler Description

The Gasmaster GMI 8M series are gas-fired boilers with nominal input rating of 8,000,000 Btu/hr. Each unit consists of one stainless SA312, Type 304, 10-3/4" schedule 40 machined (grooved) central hubs and one end coil. Coiled around each hub is a 1 1/4" SS tube type 316L with minimum wall thickness of 0.065". In between the two coils, there are twenty two 316L stainless steel coils without the central hub (please see Figure 1, below). All coils are held parallel in a vertical plane, at a predetermined distance, by clamps that are connected by three SS spacers/ready rods and adjustment nut assemblies.

Water enters each coil at the perimeter and exits at the center (near the burner), thus allowing for a gradual pick up of heat as the water circulates through the coil. The inlets of all coils are connected to the two inlet stainless steel manifolds. The outlets of coils are connected to tube sheet assembly. The tube sheet assembly is bolted onto the outlet manifold. The inlets are horizontal and the outlet is vertical. The space in the central part of the coils defines the combustion chamber of the boiler. The volume outside the coils and inside the boiler liner is the boiler chamber.

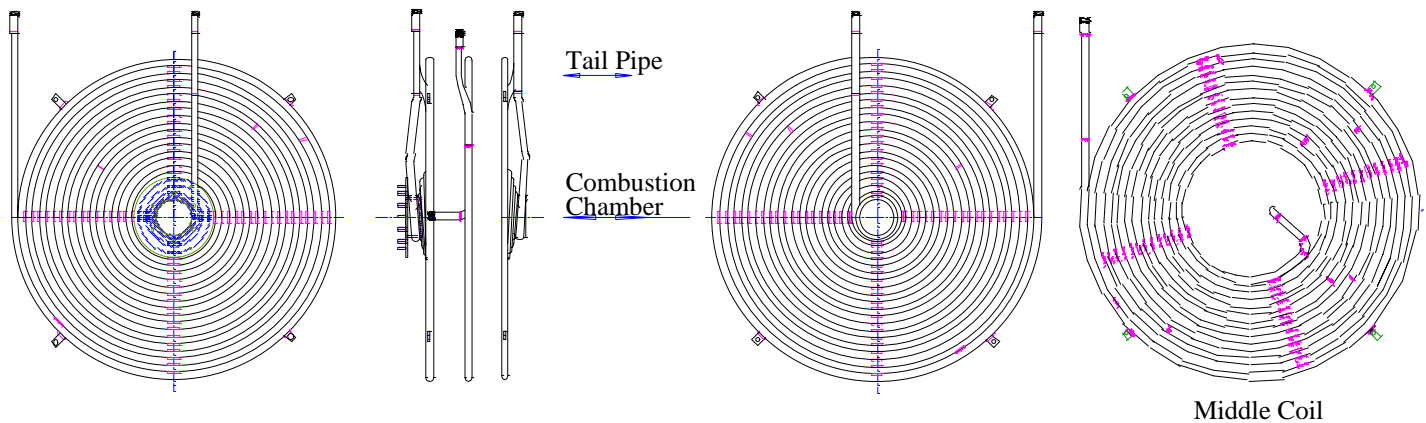

**Figure 1:** Heat Exchanger Configuration

Three stainless steel ready rods (running through the tabs) connect the coils to the side legs of the housing. The unit's housing (casing) comprises inside and outside panels constructed from 14 and 18 gauge stainless steel plates. Two-inch fiberglass insulation is sandwiched between the inner and outer panels. Combustion products exit the housing through a 24" diameter exhaust outlet on the top panel. A catch tray is secured to the base of the housing for collection of the condensate. The condensate exits the housing through an outlet at the bottom left of the boiler.

Air and gas mixture enters the combustion chamber through the burner nozzle/head. The boiler utilizes turbulent combustion technology that allows for compact sized combustion chamber, high efficiency, and low NOx operation. Heat transfer from combustion flame to water takes place in a turbulent mode. Water flows through the coils under high speed and in turbulent mode. Furthermore, unlike conventional boilers where heat transfer from hot combustion gases to water takes place in a "natural convection" mode, the flame and combustion gases in Gasmaster products directly "impact" on the surface of coils, transferring heat through conduction and "forced

convection”. Finally, heat is transferred through a “counter flow” process. That is, at any given point along the surface of heat exchanger, maximum temperature difference is achieved between water and flame/combustion gases. These factors result in a highly efficient process for heat transfer from combustion flame and exhaust gases to water.

## ***1.2 Control System***

The boiler control module consists of an “Individual Boiler Control Module”, or the “BMS” (Boiler Management System) signal input module as an option.

With the “Individual Boiler Control Module”, the unit’s operation is governed by the desired outlet (hot water) temperature. Using a digital, high precision temperature controller, the owner will identify the required hot water temperature. A temperature sensor installed on the boiler outlet manifold continuously measures the outlet water temperature.

A servomotor controlling the gas butterfly valve and the air damper (by means of a variable profile cam mechanism) allows for throttling of the air/gas mixture flowing into the burner. For as long as the set temperature is above that of the outlet water, the boiler operates at maximum output capacity. An output signal from the temperature controller, throttles the flow of gas and combustion air in the gas butterfly valve and the air damper. Therefore, the appropriate volume of air/gas mixture flows into the burner, allowing for almost perfect air/gas mass, and volume ratios. As the outlet temperature approaches the set temperature, the air/gas mixture flow is gradually reduced by the servomotor (connected to the gas butterfly valve and the air damper). This results in the corresponding gradual decrease in the unit’s capacity. Thus the throttle system allows for optimum continuous operation of the boiler, significantly reducing on/off cycles. The said system offers the user almost infinite modulating capacity within the boiler operating range.

## ***1.3 Safety Features***

Each Gasmaster GMI 8M boiler is equipped with a number of safety features.

- I: Low Water Cut Off Switch:*** One “McDonnell & Miller” low water cut off switch is installed on the outlet manifold. When the water reaches the LWCO position, the burner should fire.
- II: Flame Sensor:*** A flame probe is used as a flame proving sensor. This is connected to the burner controller, and is installed inside the burner head. At any time after the main gas valve is opened, if flame is not detected for a period longer than 4 seconds, the burner controller will be deactivated and the main gas valve will immediately close.
- III: High Temperature Limit:*** Each unit is equipped with a “Honeywell” high temperature limit switch. If outlet water temperature exceeds the temperature set on this switch, the burner controller will be deactivated and the gas valve will immediately close.
- IV: Air Pressure Switches:*** One low air pressure switch is installed on the side of the burner/blower and measures air pressure entering the burner (for exact location of

the switch please see item #15 on the drawing presented on page 4 of the Riello catalogue). If the combustion air pressure drops by more than 20% below the nominal air pressure (minimum pressure of 0.4" wc), the burner controller will be deactivated and the main gas valve will immediately close.

**V: *Relief Valve:*** A "Conbraco" safety relief valve with prescribed nominal pipe size of 1 1/2" valve inlet/outlet, and discharge capacity of 11,871,000 Btu/hr and 150 psig relief pressure, is installed on the water outlet manifold and supplied as standard equipment. When the boiler is used in heating applications having working pressures in the range 40–160 psig, an appropriate pressure relief valve should be installed.

**VI: *Gas Pressure Switches:*** One manual reset low gas pressure switch is installed on the gas train in between the gas pressure regulator and the first safety shut off valve (please see the schematic diagram "Typical UL Schematic Gas Piping" on page 9 of the Riello catalogue). If the line pressure drops below 0.5" wc, the switch will open and the unit will immediately shut down. One high gas pressure switch is also installed on the side of the Riello burner (for exact location please see item #4 on the drawing presented on page 4 of the Riello catalogue). If the gas manifold pressure increases above 20" wc, the switch will open and the unit will immediately shut down.

## **1.4 Gas Lines**

### **1.4.1 Pilot Gas Line**

Referring to the "Typical UL Schematic Gas Piping" diagram on page 9 of the Riello catalogue, gas from the main supply line flows at the pressure range of 1- 5 psi through the manual valve into the pilot line and main line. The gas in pilot line will flow through the regulator and the safety shut off valve into the burner. The pressure regulator is adjusted such that gas flows within 2"–5" wc pressure into the safety shut off valve. If pilot flame is not established within 5 seconds of the ignition time, the flame safeguard will shut off the pilot safety gas valves and burner locks out (Riello catalogue, page 16).

The pilot flame will ignite the air/gas mixture flowing through the burner within 5 seconds of the mixture flowing into the burner otherwise it locks out (Riello catalogue, page 16).

### **1.4.2 Main Gas Line**

Referring to the same drawing, main supply line gas flows (at a pressure of 1-5 psig) through the manual gas valve into the main gas line. The gas into the main gas line flows through the two safety shut off valves and pressure regulator. Finally gas flows through the gas adjustment butterfly valve into the burner where it is ignited by the pilot flame. The pressure regulator is adjusted such that the manifold gas pressure remains within 1.6"–12" wc. This pressure is tested at the manifold gas pressure test point located on the top of the Riello burner (for exact location of the test point please see item #17 on the drawing presented on page 4 of Riello catalogue). Signals from the temperature controller are sent to the servomotor, which controls the opening of the butterfly valve and the air damper. Subsequently, the valve and damper are proportionately closed

or opened in order to decrease or increase the air/gas mixture flow into the burner. Hence, maintaining the outlet water at constant temperature, during changes in the load/demand (i.e. throttle or load tracking function).

### **NOTES**

- *Air and gas flow rates are factory adjusted for optimum combustion quality. Note that these settings may vary slightly at different site conditions (calorific value of gas, duct length, etc.).*
- *After installation is completed, using a gas analyzer, the CO and O<sub>2</sub> contents of the exhaust gases should be re-checked to ensure their compliance with those achieved at the factory and reflected in the test report provided to your local Gasmaster representative.*
- *IF adjustments to the factory settings of air and gas flows are made, ensure that the manifold gas pressure does not exceed the 12" wc specified on boiler label.*

### **WARNING**

*Exceeding the maximum allowable gas manifold pressure could result in over-firing of the unit and may cause permanent damage to the unit.*

## ***1.5 Gas Manifold and Control Assembly Tests***

Safe operation and all performance criteria of all Gasmaster products, incorporating the installed gas manifold and control assembly, are proven before delivery when the products are factory tested in accordance with the latest revision of CSA CAN 1-3.1-77 and UL 795 standards.

## ***1.6 Code Compliance***

In Canada, boiler installation must conform to the requirements identified in the CSA B149.1 for gas burning appliances, CSA Codes B51 for boiler, pressure vessel, and pressure piping, and/or all applicable local codes. All electrical connections are to be made in accordance with the requirements of CSA C22.2, No. 3 electrical features of fuel burning equipment and No.0 general requirements- Canadian Electrical Code, Part 1 and /or all applicable local codes.

In the United States of America, the installation must conform to the requirements of the authority having jurisdiction or, in the absence of such requirements, to the National Fuel Gas Code, ANSI Z223.1-latest edition. All electrical wiring must be carried out in accordance with the National Electrical Code ANSI/NFPA No.70-latest edition and The Canadian Electrical Code, and any additional state or local code requirements. If an external power source is used, the unit must be electrically grounded in accordance with the requirements of the authority having jurisdiction. In the absence of such authority, the boiler must be electrically grounded in accordance with the National Electrical Code ANSI/NFPA No. 70-latest edition and The Canadian Electrical Code.

The plumbing and condensate disposal must be carried out in accordance with the local plumbing codes.

### ***NOTES***

- *Boiler can be used in both closed loop and open loop (one pass) operations.*
- *In the commonwealth of Massachusetts the installation shall be carried out by a licensed gas fitter/plumber and comply with 48CMR*

## ***1.7 Freeze Protection***

- When used in an open or closed loop configuration, whenever necessary, the boiler or must be drained. Due to the radial geometry of the unit, it must be drained by forced air only.
- When used in a closed loop configuration, if absolutely necessary, system antifreeze can be utilized, in which case the boiler or does not need to be drained. The antifreeze must be compatible with hydronic heating systems.

## ***1.8 Water Treatment***

All heat exchanger coils are constructed from high grade stainless steel. Therefore, high oxygen content in the feed water should not result in any corrosion inside the coils. Since water flow through coils is in turbulent mode, and they are continuously expanding and contracting; the operation of the unit is to a large extent self cleaning. Therefore, other potential minerals that may exist in water should not have any adverse effect (on the tubes). However, if it is wished to supply soft water to the boiler or, then a sodium-based ion-exchanger may be used. Note that generally “soft water” is defined as one having less than 1.2° British, or 17° US hardness level. Consult a local water treatment consultant to determine if boiler water treatment is required. Water treatment is highly recommended because it will increase the life of the boiler.

**SECTION 2:**  
**INSTALLATION**

## **2.1 Boiler Package**

Each unit is supplied with:

1. Riello burner/blower.
2. Inlet and outlet manifolds.
3. High temperature cut off switch with manual reset. (On outlet manifold)
4. Operating temperature switch. (Inside burner)
5. Pressure relief valve. (On outlet manifold)
6. Main gas valves.
7. Fully assembled gas piping.
8. One low water cut off switch. (On outlet manifold)
9. One flow switch. (On outlet manifold)
10. One air pressure switches (On gas valve)
11. Two gas pressure switches, one low and one high. (On gas train)
12. One temperature sensor installed on the outlet manifold and connected to the control burner.
13. Flame Rod (inside burner)
14. Flame sensor (inside burner)
15. Condensate drain connection. (On boiler)
16. Flue gas connection. (On boiler)
17. Pressure gauge. (On outlet manifold)
18. One vent valve installed on the outlet manifold.

Please contact Gasmaster Industries if items listed above are missing. Please be familiar with major parts of the boiler before operating. Always exercise caution when transporting. Instructions provided are only general guides, and are not substitute for common sense and sound safe practices.

## **2.2 Location**

- I:** This boiler is for indoor installation only.
- II:** For service access to the Riello control box, condensate drain “U” trap, and gas train, refer to the clearances indicated on the boiler rating plate. Note that some jurisdictions may have their own clearance requirements. In such cases refer to all applicable local codes.
- III:** The boiler can be placed in a basement or utility room. It should not be placed in an unconditioned area where the unit and condensation could be subject to freezing temperatures.
- IV:** For reduced installation cost, locate the boiler as close to an outside wall as possible.
- V:** Flue gases must be vented in accordance with the local codes and in absence of local codes with the CSA B149.1 or ANSI Z223.1.
- VI:** Keep boiler area clear and free from combustible materials, gasoline, flammable vapors and liquids.
- VII:** Ensure that inlet to the blower is kept clear of any obstruction so that combustion air can flow freely through to the air intake blower.
- VIII:** A resilient pad to separate the boiler from floor IS NOT REQUIRED.
- IX:** Refer to burner manufacturer manual for Air requirement into the burner. Provide 2000 CFM or the air recommended by burner manufacturer whichever is greater. The boiler installer must provide the proper size or dimensions of minimum air opening into room based on the location of installation, altitude and in accordance with the local codes and in absence of local codes with the CSA B149.1 or ANSI Z223.1.
- XI:** Transportation  
Lift only from the bottom welded frame. Never lift from the manifold  
Avoid bottom condensate drain and the gas line.  
Burner should be supported during moving.  
Center of the mass of the boiler is about 28” from the front edge of the panel.  
Lift the boiler straight up and install moving pads. Do not tilt the boiler more than 5 degree.

## **2.3 Relief Valve**

A pressure relief valve is supplied as standard equipment. The relief valve is a mandatory protection against damage that could be caused by excessive water pressure. Mal-functioning of boiler controls can build up heat and excessive pressure to destroy the boiler.

The pressure relief valve should be connected to a suitable water drain. The drain pipe **MUST** pitch down from the valve and its internal diameter should not be less than that of the relief valve. The end of the drain line should not cause any restriction to the water flow, and should be protected from freezing. There should not be any valve installed between the pressure relief valve and the end of the drain line. Similarly, there should not be any instrument installed anywhere along the length of the drain valve, between the relief valve and the end of the drain line. The relief valve is installed in vertical position and should remain in that position at all times.

## **2.4 Water Connection**

All pre-installation work has been completed at the factory. Three water manifolds (two inlet and one outlet headers) are provided with the unit. One low water cut off switch is installed on the outlet manifold. One high temperature limit switch and one pressure relief valve are installed on the outlet manifold. A thermocouple installed on the outlet manifold is connected to the appropriate terminals in the Riello control box.

Cold-water inlets and hot water outlet connections are clearly marked on the respective manifolds of the boiler. The cold water supply line (in one pass applications), or return water (in closed loop applications) should be connected to the cold water inlet of the unit. The hot water supply line should be connected to the hot water outlet of the boiler. Both manifolds have 4" stainless steel flange, ANSI B16.5#150 lbs inlet/outlet connections. Use minimum Grade 5 bolts (5/8-unc), carbon steel and applicable lock washer and nuts. Torque the bolts and check the torque rating. Ensure a water tight gasket, if used, is not destroyed by the applied torque.

Insulate the outlet manifold with applicable insulation to reduce heat loss is highly recommended.

For further information on methods of connecting supply and return water piping to boilers consult available installation and piping guides developed according to local plumbing codes.

## **2.5 Condensate Line**

Connect 3/4" ABS tubing from the condensate drain "U" trap, directly to the floor drain. Notice that the line **MUST** be pitched downward towards the floor drain to avoid traps. **DO NOT** install any valve of any type, or any other instrument between the condensate drain "U" trap and the end of the condensate line. If the condensate is properly drain or is trapped inside the boiler, the boiler will not operate properly.

## **NOTE**

- *To ensure proper flow of condensate, it is recommended to install a “drain vent” of approximately 1 foot height at 0.5-1 foot downstream of the U trap.*

## **2.6 Gas Line Connections**

The gas train comprises a low gas pressure switch, solenoid valves and pressure regulator, and the main gas valve. Gas pressure at the inlet to the gas line should be 1-5 psi. If higher pressures are present, consult the local gas company or gas installation codes for installing the appropriate gas pressure regulator. Gas line from the meter to the boiler should be of adequate size to prevent undue pressure drop. A manual shut off valve should be installed in the gas line upstream of the solenoid valves and pressure regulator, so that the control instruments (solenoid valves, regulator, and low gas pressure switch) could be easily isolated and removed, whenever necessary. The valve should be clearly marked, located outside the unit’s housing, readily visible and accessible for turning on and off. The valves need to be certified for gas application.

## **NOTE**

- *Inlet gas pressure upstream of the unit(Gas train ) must be 1-5 psi*

## **NOTE**

- *Install a trap at the inlet of the gas connection of the unit.*

## **2.7 Vent Connection**

Connect a 24” ID vent to the exhaust gas outlet on the boiler top panel. Any type of venting installation (i.e. horizontal or vertical either through side wall or through a chimney using an exhaust fan, power vent or draft inducer or without) is dictated by local codes and in absence of local codes must be in accordance with the CSA B149.1 or ANSI Z223.1.

## **NOTES**

- *This product must be vented in accordance with the local codes and in absence of local codes with the CSA B149.1 or ANSI Z223.1*

## **Equivalent Lengths**

90 deg. Elbow	3'
45 deg. Elbow	2'
Condensate Tee	2'
Vent Cap	3'

## **NOTES**

- *The exhaust venting system must meet the requirements of boilers with corrosion resistant, water and air-tight venting system.*
- *The exhaust duct outlet to the atmosphere **MUST** be wind protected by an approved wind cap.*

### **2.7.1**

When an existing boiler is removed from a common venting system, the common venting system is likely to be too large for proper venting of the appliances remaining connected to it. Therefore:

At the time of removal of an existing boiler , the following steps should be followed with each appliance remaining connected to the common venting system placed in operation, while the other appliances remaining connected to the common venting system are not in operation

- I:** Seal any unused openings in the common venting system.

- II:** Visually inspect the venting system for proper size and horizontal pitch and determine there are no blockages, restrictions, leakage, corrosion or other deficiencies, which could cause an unsafe connection.
- III:** Insofar as is practical, close all building doors and windows and all openings between the space in which the appliances remaining connected to the common venting system are located and other spaces of the building. Turn on the clothes dryers and any appliance not connected to the common venting system. Turn on any exhaust fans, such as range hoods and bathroom exhausts, so they will operate at maximum speed. Do not operate a summer exhaust fan and close fireplace dampers.
- IV:** Place in operation the appliance being inspected. Follow the lighting instructions; adjust the thermostat so the appliance will operate continuously.
- V:** Test for spillage at the draft hood relief opening after 5 minutes of main burner operation. Use the flame of a match, candle, or smoke from a cigarette, cigar or pipe.
- VI:** After it has been determined that each appliance remaining connected to the common venting system properly vents, when tested as outlined above, return doors, windows, exhaust fans, fireplace dampers and any other gas-burning appliance to their previous condition of use.
- VII:** Any improper operation of the common venting system should be corrected, so the installation conforms to the National Fuel Gas Code, ANSI Z223.1 or the CSA B149.1. When resizing any portion of the common venting system, the common venting system should be resized to approach the minimum size as determined using the appropriate tables in Appendix G in the National Fuel Gas Code, ANSI Z223.1 or the CSA B149.1.

## 2.7.2

For connection to gas vents or chimneys, vent installations should be in accordance with Part 7, Venting of Equipment, of the National Fuel Gas Code, ANSI Z223.1 or the CSA B149.1, or applicable provisions of the local building codes.

Vent connectors serving appliances vented by natural draft should not be connected into any portion of mechanical draft systems operating under positive pressure.

The horizontal portions of the venting system should be supported to prevent sagging. The methods of and intervals for support should be in accordance with the local code standards. Furthermore, the following installation requirements should also be satisfied:

- I:** Horizontal runs should slope upwards not less than 1/4" per foot (21 mm/m) from the boiler to the vent terminal.

**II:** The vent system should be installed to prevent accumulation of condensate.

**III:** Where necessary, the vent system must provide the means for drainage of condensate.

### 2.7.3

Vent termination should be in accordance with all applicable local codes. In addition, the following conditions must be satisfied:

**I:** Distances from adjacent public walkways, buildings, windows and building openings, should be consistent with the National Fuel Gas Code, ANSI Z223.1 or the CSA B149.1.

**II:** Minimum clearance of 4 feet (1.22 m) horizontally and in no case above or below, unless a 4-foot (1.22 m) horizontal distance is maintained from electric meters, gas meters, regulators and relief equipment.

### 2.7.4

It is recommended to install prefabricated factory-made vent parts each designed to be assembled with the other without requiring field fabrication.

<b>MANUFACTURER</b>	<b>VENT PART MODEL</b>	<b>MATERIAL</b>
Heat-Fab Inc.	Saf-T Vent system	Stainless Steel

## 2.8 *General Instructions*

### 2.8.1

The boiler and its individual shutoff valve must be disconnected from the gas supply piping system during any pressure testing of that system, at test pressures in excess of 5 psig. The unit must be isolated from the gas supply piping system by closing its individual manual shutoff valve, during any pressure testing of the gas supply piping system at test pressures equal or less than 5 psig.

### 2.8.2

The boiler should be installed such that the gas ignition system components are protected from water (dripping, spraying, rain, etc.) during appliance operation or service.

### **2.8.3**

The boiler and its gas connection must be leak tested, before placing the boiler in operation.

### **2.8.4**

The boiler when installed must be electrically grounded and bonded in accordance with the local codes or in the absence of such codes, in accordance with the National Electrical Code, ANSI/NFPA 70 and the Canadian Electrical code.

### **2.8.5**

The boiler should be located in an area where leakage of the tank, or connections, will not result in damage to the area adjacent to the appliance or to the structure. When such locations cannot be avoided, it is recommended that a suitable drain pan, that drains adequately be installed under the boiler. The pan must not restrict air- flow.

### **2.8.6**

The boiler is a fairly complex and expensive equipment. The instructions provided require a lot of common sense but require a great deal of care. The people handling the unit should be experienced with proper training. Please understand the complete unit and its parts before operating.

**SECTION 3:**  
**OPERATION**

## 3.1 Sequence of Operation

### 3.1.1 Safety Loop

#### A: Components

Referring to Control System Schematic, the safety loop includes the following components:

- I: High temperature cut off switch:** This is a manually reset switch and is normally closed. It is installed on the outlet manifold. The desired high limit temperature is set by the owner and is usually 10 °F above the maximum operating (alarm) temperature. In no event should this switch be set at above 210 °F (it is fixed in the factory). If the outlet temperature increases above the set temperature, this switch will open and the unit will go into the “lock-out” mode. The unit will remain in this mode until the operator manually resets the switch.
- II: Maximum operating (alarm) temperature switch:** This switch is normally closed and is embedded in the temperature controller unit. The maximum operating temperature should be set on this display. The desired outlet temperature (desired set point) is also set by the owner on the same temperature controller.
- III: Low water cut off switch:** This switch is installed in the end of manifold. The switch is normally open, and as soon as water level in the system reaches the point where the switch is installed, it will close.
- IV: Remote Enable/Disable Terminals:** There are “Remote Enable/Disable” terminals in the control panel. These terminals can be used for the BMS connections, if required.
- V: High and Low gas pressure switches:** A manual reset low gas pressure switch is installed on the gas train before the first safety shut off valve (please see item #4 on the schematic diagram “Typical UL Schematic Gas Piping” on page 9 of the Riello catalogue). If the line pressure drops below 0.5 psi, the switch will open and the unit will immediately shut down. One high gas pressure switch is also installed on the side of the Riello burner (for exact location please see item #4 on the drawing presented on page 4 of the Riello catalogue). If the gas manifold pressure increases above 20” wc, the switch will open and the unit will immediately shut down.
- VI: Air Pressure Switches:** One low air pressure switch is installed on the side of the blower (on Riello burner) and measures air pressure entering the burner (for exact location of the switch please see item #15 on the drawing presented on page 4 of the Riello catalogue). If the combustion air pressure drops by more than 20% below the nominal air pressure, the burner controller will be deactivated and the main gas valve will immediately close.

## **WARNING**

*Do not bypass any of the instruments in the safety loop. Doing so may cause serious damage to the unit and its surroundings.*

### **B: Sequence of Events**

- I:** Every boiler is fully tested at the factory prior to shipment. When the unit is tested at the factory, contacts of SW switch between terminals 3 and 20 identified as “Remote Enable/Disable” (see electrical diagram). If BMS is used, these terminals should be connected to wires from the BMS. In the absence of a BMS, the operation of the unit is governed by the temperature controller.
  
- II:** Once the blower starts operating, the air pressure switch (on Riello burner) will close. This switch has been factory adjusted such that when the blower reaches its minimum frequency it will close.

#### **3.1.2 Pre-Purge**

- I:** When the air pressure switch (on Riello burner) is closed and safety loop is satisfied, pre-purge will start.
  
- II:** Blower continues to run at its maximum frequency for a period of 30 seconds.

#### **3.1.3 Pilot Flame**

- I:** After completion of the pre-purge period, the burner controller sends the required high voltage to the ignition rod, and 120V to the pilot safety shut off valves. The valves open simultaneously with the activation of the ignition rod. Upon pilot ignition, and after the flame is detected by the sensor, the ignition rod will be deactivated.
  
- II:** If after 2.5 seconds activation of the flame rod and opening of the gas valves, pilot flame is not established and detected by the flame sensor, the gas valves will immediately shut down and the boiler goes into the “lock-out” mode. The unit will not re-start until the burner controller is manually reset.

### ***3.1.4 Main Flame***

- I:*** Once pilot flame is established burner controller will send 120V to the two main safety shut off valves. From these valves gas flows into the gas butterfly valve (see schematic diagram on page 9 of the Riello catalogue).
- II:*** Air supplied by the blower flows through to the burner head where it mixes with gas and the air/gas mixture is ignited by the flame rod.
- III:*** The pilot safety shut of valves will close five seconds after the main safety valves are opened. If at any time during the operation flame (pilot or main) is not detected the burner will lock out within 1 second and boiler will shut down and will not restart until the burner controller is manually reset.

### ***3.1.5 Operation***

The unit continues to operate at low fire for as long as the outlet (discharge) temperature remains higher than the desired temperature and lower than the maximum operating (alarm) temperature, both being set on the temperature controller. The thermocouple installed on the outlet manifold continuously measures the discharge water temperature. Signals from this thermocouple are sent to the temperature controller. If the temperature measured by the thermocouple is below that of the desired temperature, corresponding signals are sent to the servomotor. This will open the gas butterfly valve and air damper proportionately thereby increasing the input capacity of the unit, to its maximum value at high fire. As soon as the discharge water reaches the desired temperature (set on the temperature controller by the owner), the process is reversed and the input is decreased so that discharge water remains at constant temperature. This throttle (load tracking) process continuously takes place through increase or decrease in the air/gas mixture (opening/closing of the butterfly valve and air damper); thereby ensuring water is always supplied at  $\pm 1$  °C of the desired operating (discharge) temperature.

If the water temperature reaches the maximum operating (alarm) set point, the boiler will shut down and goes into the stand by mode. The unit will automatically re-start when the water temperature drops below the operating set point minus the differential temperature.

#### ***NOTE***

## **3.2 PRE-COMMISSIONING**

### ***I: Water connections (Return and Supply Lines)***

- Purge air from the heater coils will decrease localized heat build up and increase the life of the boiler.  
To purge the unit, pump cold water through the boiler at about 30 psig pressure difference between the inlet and outlet manifolds for at least 5 minutes. Shut the main water valve on and off and listen for air bubbles circulating through the pipe.
- Drain the boiler regularly for maintenance.  
To drain the coils, isolate and seal the boiler inlets and outlet water connections. Open the bottom drain valve on the lower front side of the boiler to drain water in the rear ellipsoidal cap.  
Connect a compressed air line to a 3/8" tee and connect the tee to the 3/8" vent valve on the outlet manifold.  
Close the bottom drain, and open the 3/8" vent valve. Cycle the two valves for 20 second interval.  
By venture effect, the water in the coils will have moved to the dish end for draining.  
Continue the cycling the two valves until no water flow out.

### ***II: Gas Connections***

- All pipe connections should be carried out in strict compliance with all applicable local codes.
- Selection of the gas regulator model and size (if any) should be carried out in accordance with the design requirements.
- Conduct a complete leak test on the unit's gas train, and all gas lines connected to it.
- Measure the static pressure upstream of the unit to ensure it is within the prescribed range of 1-5 psi.

**III: Vent Connection**

- Installation must be carried out in accordance to all applicable local codes and factory guidelines.
- When required, a proper drain should be installed on the vent.

**IV: Condensate Line Connection**

- Inspect the condensate line and ensure it is installed in accordance with the factory guidelines.

**V: Power Connection**

- Inspect all wiring connections to the unit and ensure they comply with all applicable local codes.
- Ensure that the appropriate power supply has been connected to the unit (please refer to the electrical rating on the unit's nameplate).
- Ensure the temporary jumpers have been removed from the unit's control panel.
- If applicable, ensure the external control connections have been wired.

**WARNING**

*Ensure the manual gas valve is closed prior to power being supplied to the boiler*

**NOTE**

- *Start-up and commissioning MUST be carried out by a GMI qualified technician.*

## **WARNING**

*The field start-up report MUST be faxed to GMI at 604-574-9572 within 10 days of start-up. Failure to do so will result in cancellation of all expressed and/or implied warranties.*

### **3.3 Commissioning**

- I:** Purge heat exchanger coils in accordance with the procedure outlined in paragraph **I** of section 3.2.
- II:** Measure flow rate through the unit to ensure a minimum of 80 GPM is available through the unit.
- III:** Connect the power supply cord to the 208V outlet. Turn the “ON/OFF” switch (located on the front panel of the Riello blower/burner assembly) to the “ON” position.
- IV:** After the system has undergone the sequence of events described in Section 3.1 above and when the two safety shut off valves in the main gas line are opened, the unit will be in regular operating mode.
- V:     *Test Points***
- Measure gas inlet pressure upstream of all safety shut off valves and the gas pressure regulator to ensure it is within the specified range of 1 – 5 psi.
  - Measure the gas manifold pressure at the test point located adjacent to the burner’s gas inlet connection port (for exact location please see item #17 of the drawing presented on page 4 of the Riello catalogue), ensure it is within the specified 1.6”– 12” wc.
  - Measure the manifold air pressure at the test point located on the side of the burner (please see item #18 on page 4 of the Riello catalogue). Ensure this pressure is between 0.4” – 1.4” wc.

## **WARNING**

*The gas manifold pressure should not exceed the maximum value shown on the unit's nameplate.*

### **3.4 GENERAL INSTRUCTIONS**

- I:** Should overheating occur or the gas supply valve fails to shut off, do not turn off or disconnect the electrical supply to the pump. Instead, shut off the gas supply at a location external to the unit. Allow the water to continue to circulate through the boiler and cool the boiler naturally. After the boiler is sufficiently cool, isolate the boiler from the water system, shut down the boiler, and call for inspection.
  
- II:** **Do not use this boiler if any part has been under water.** Immediately call a qualified service technician to inspect the boiler and to replace any part of the control system or any gas control component, which has been under water.

# GASMASTER INDUSTRIES BOILERS GMI SERIES

## FOR YOUR SAFETY READ BEFORE OPERATING

**WARNING:** If you do not follow these instructions exactly, a fire or explosion may result causing property damage, personal injury or loss of life

- A. This appliance is equipped with an ignition device, which automatically lights the pilot. Do not try to light the pilot by hand. Do not relight the pilot or start burner with the combustion chamber full of gas, or with very hot combustion chamber.
- B. BEFORE OPERATING, smell all around the appliance area for gas. Be sure to smell next to the floor because some gas is heavier than air will settle on the floor.

### WHAT TO DO IF YOU SMELL GAS

- Do not try to light any appliance.
- Do not touch any electric switch; do not use any phone in your building.
- Immediately call your gas supplier from a neighbor's phone. Follow the gas supplier's instructions.
- If you cannot reach your gas supplier, call the fire department.
- C. Use only your hand to push in or turn the gas control knob. Never use tools. If the knob will not push in or turn by hand, don't try to repair it, call a qualified service technician. Force or attempted repair may result in a fire explosion.
  - D. Do not use this appliance if any part has been under water. Immediately call a qualified service technician to inspect the appliance and to replace any part of the control system and any gas control, which has been under water.
  - E. Refer to boiler Manual for part list, definition, installation and operation details, and general maintenance. Maintain this instruction and the boiler manual in legible condition.
  - F. The installer will identify the emergency shut-off device.

## OPERATING INSTRUCTION

1. STOP! Read the safety information above on this label.
2. Turn OFF all electric power to the appliance, including the power switches on the control box.
3. Set the thermostat (or temperature controller) to the lowest setting.
4. This appliance is equipped with an ignition device, which automatically lights the burner. Do not try to light the burner by hand.
5. Close manual gas valve, turning to "OFF" position. Do not force.
6. Wait five (5) minutes to clear out any gas. Then smell for gas, including near the floor. If you smell gas, STOP! Follow "B" in the safety information above on this label. If you don't smell gas, go to the next step.
7. Open manual gas valve, turning to "ON" position.
8. Set the thermostat (or temperature controller) to desired setting.
9. Turn on all electric power to the appliance, including the power switches on the control box.
10. If the appliance will not operate, follow the instructions "To Turn off Gas to Appliance" and call your service technician or gas supplier.

### TO TURN OFF GAS TO APPLIANCE

1. Set the thermostat (or temperature controller) to lowest setting.
2. Turn off all electric power to the appliance if service is to be performed.
3. Close manual gas valve, turning to "OFF" position. Do not force.

---

**SECTION 4:**  
**MAINTENANCE**

## **4.1 Service Hints**

- I:** Gasmaster boilers have been designed and developed based on a unique patented technology. When operated properly, the products will provide the owner with years of trouble free performance. To benefit for many years, from the unique performance characteristics of these boilers, it is recommended to have your boiler inspected by a qualified service person at least once every year.
- II:** Ensure that air intake and exhaust ducts are always free of any debris and restrictions. This will allow the electric motor to operate under normal loads, as well as allowing for a clean combustion process. Do not store anything against the boiler and ensure that the boiler is kept in a clean environment. Do not store any combustible material, flammable liquid, or vapor, in the vicinity of the boiler.
- III:** Should overheating occur or the gas supply fails to shut off, turn off the manual gas control valve. Allow the water to circulate through the boiler to cool naturally. Call for inspection after the boiler can be safely shut down and isolated from system.
- IV:** Label all wires prior to disconnection when servicing the controls. Wiring errors can cause improper and dangerous operation.
- V:** Verify proper operation after each service (refer to the start-up report).
- VI:** The following precautions should be taken at least once a year:
- Check the condensate drain line (including the “U” trap) to ensure there is no restriction in the line.
  - Check the duct to ensure there is no restrictions or signs of rust. Ask your service person to clean the duct, if required.
  - Inspect the sheet metal covering the insulation for any sign of rust or corrosion. If necessary, contact your service person to clean the sheet metal panels.
  - Inspect all flue gas passageways, including the inner surface of the heat exchanger for any sign of rust, corrosion or obstructions. If necessary, contact your service person to clean the surfaces.
  - Inspect the central plate and the burner for any sign of damage or corrosion. Contact your service person for cleaning the surfaces or replacement of the component, if necessary.
  - Confirm all safety controls, ignition system, valves are functioning properly and check for leakage across safety shut off valves.
  - If boiler turned off for extended period of time, set the thermostat(or temperature controller) to the lowest setting, turn off all electric power to the appliance and shut off the main supply gas valve(turning to “off” position).
  - Check for gas leaks along the main gas line.
  - Check for carbon build up on the coils and consider cleaning coils.
  - Check for flue gas leak along boiler casing and ducts.
  - Check mineral content of water enter the boiler for possible water treatment.

## 4.2 Troubleshooting

Fault	Cause	Corrective Action
<ul style="list-style-type: none"> <li>◆ Blower does not start</li> </ul>	<ul style="list-style-type: none"> <li>◆ Power not supplied to the unit.</li> <li>◆ Safety loop open.</li> <li>◆ None of the above</li> </ul>	<ul style="list-style-type: none"> <li>◆ Ensure power switch is on.</li> <li>◆ Check all fuses on the power and the supply sides.</li> <li>◆ Ensure BMS (if connected) calls for heat.</li> <li>◆ Ensure high temperature limit switch is closed.</li> <li>◆ Ensure maximum operating (alarm) temperature switch is closed.</li> <li>◆ Ensure low and high gas pressure switches are closed.</li> <li>◆ See page 20 of the Riello catalogue for burner controller trouble shooting.</li> </ul>
<ul style="list-style-type: none"> <li>◆ Unit does not start</li> </ul>	<ul style="list-style-type: none"> <li>◆ Blower does not run.</li> <li>◆ Air pressure switch is open.</li> <li>◆ Gas pressure switch is open.</li> <li>◆ No ignition.</li> </ul>	<ul style="list-style-type: none"> <li>◆ See above</li> <li>◆ Adjust switch.</li> <li>◆ Replace switch (if defective).</li> <li>◆ Adjust the switch.</li> <li>◆ Replace switch (if defective).</li> <li>◆ See page 20 of the Riello catalogue for burner trouble controller trouble shooting</li> </ul>
<ul style="list-style-type: none"> <li>◆ Pilot flame failure</li> </ul>	<ul style="list-style-type: none"> <li>◆ Pilot gas valve not opened</li> <li>◆ No ignition</li> </ul>	<ul style="list-style-type: none"> <li>◆ Check the electrical connections to ensure they are all securely connected (see the schematic wiring .diagram for terminals).</li> <li>◆ Check the two safety shut off valves. Replace if defective.</li> <li>◆ Check the electrical connections to ensure they are all securely connected (see “Factory Wiring Diagram” on pages 18 and 19 of the Riello catalogue) for terminals.</li> <li>◆ Check the flame rod to ensure it is clean and free of any sedimentation. Clean flame rod if necessary.</li> <li>◆ Check the flame rod for any cracks or other defects. Replace flame rod if necessary.</li> <li>◆ Measure gas pressure in the pilot line at the exit test port of the second safety valve (downstream of the regulator). Ensure it is within the specified 2”-5” wc. If pressure is not available check both safety shut off valves and the pressure regulator. Replace any defective component, if necessary.</li> </ul>

<ul style="list-style-type: none"> <li>◆ Main flame failure</li> </ul>	<ul style="list-style-type: none"> <li>◆ Main gas valve not opened.</li> <li>◆ Insufficient gas pressure</li> <li>◆ Unit out of adjustment</li> <li>◆ Insufficient draft</li> </ul>	<ul style="list-style-type: none"> <li>◆ Check the electrical connections to ensure they are all securely connected.</li> <li>◆ Check the two safety shut off valves. Replace if defective.</li> <li>◆ Check gas pressure at the inlet test port of the first safety shut off valve. It should be within the specified 1-5 psi range. Adjust the pressure regulator to obtain the required pressure. If problem persists, replace the valve. Repeat process for the second safety shut off valve.</li> <li>◆ Check the gas manifold pressure to ensure it complies with the value given on boiler label and in the factory test report. If required, re-adjust the boiler/water (see factory test report for the adjustment values).</li> <li>◆ Check the vent system to ensure it is not clogged.</li> </ul>
<ul style="list-style-type: none"> <li>◆ Unit fails at frequent intervals (excessive cycling)</li> </ul>	<ul style="list-style-type: none"> <li>◆ Maximum operating (alarm) temperature is set too low.</li> <li>◆ Break in controls wiring.</li> <li>◆ Unit is over-sized</li> </ul>	<ul style="list-style-type: none"> <li>◆ Check the setting on the maximum operating (alarm) temperature switch to ensure it is set at the maximum design temperature.</li> <li>◆ If applicable, check the differential adjustment on the maximum operating temperature switch.</li> <li>◆ Check all connections to and from the wiring block located immediately below the blower.</li> <li>◆ Check the maximum heat requirement with the engineer and ensure the unit is of the appropriate size.</li> </ul>
<ul style="list-style-type: none"> <li>◆ Unclean combustion</li> </ul>	<ul style="list-style-type: none"> <li>◆ Insufficient air in the mechanical room</li> <li>◆ Unit out of adjustment</li> </ul>	<ul style="list-style-type: none"> <li>◆ Check all the louvers and air openings in the mechanical room to ensure they are free of any obstructions and there is sufficient inflow of fresh air into the room.</li> <li>◆ Using a gas analyzer re-adjust the air and gas settings.</li> </ul>
<ul style="list-style-type: none"> <li>◆ Air bubble sound in the unit.</li> </ul>	<ul style="list-style-type: none"> <li>◆ Poor water circulation in one or more coils</li> <li>◆ Foreign material in one or more coils.</li> <li>◆ Steam pockets in one or more coils.</li> </ul>	<ul style="list-style-type: none"> <li>◆ Completely purge each coil.</li> <li>◆ Drain each coil with pressurized air and re-purge.</li> <li>◆ Check water flow rate in each coil to ensure it complies with the required minimum flow rate (50 GPM).</li> </ul>
<ul style="list-style-type: none"> <li>◆ Gas Odor</li> </ul>	<ul style="list-style-type: none"> <li>◆ Leak in piping.</li> <li>◆ Exhaust gas leakage</li> </ul>	<ul style="list-style-type: none"> <li>◆ Using a gas detector, check all the connections (inlet and outlet) of all instruments on the gas line. Repair as required.</li> <li>◆ Check the vent system to ensure there are no cracks or other openings (holes cut for insertion of thermocouples during the start-up). Repair if required.</li> </ul>

# START-UP REPORT

## FIELD START UP REPORT

SERIAL NO. \_\_\_\_\_ MODEL \_\_\_\_\_ Type of Appliance \_\_\_\_\_ Label Date \_\_\_\_\_

Installation Address \_\_\_\_\_

Installer Name \_\_\_\_\_ Phone# \_\_\_\_\_ Type of Installation \_\_\_\_\_ (home, school, etc)

ELEC./CONTROL SECTION	GAS SECTION	
ALL WIRES TIGHT <input type="checkbox"/>	GAS TRAIN TIGHT <input type="checkbox"/>	
RATED VOLTAGE _____	MAIN GAS VALVE TIGHTNESS TEST <input type="checkbox"/>	
ACTUAL VOLTAGE _____	TYPE OF FUEL: NAT. GAS <input type="checkbox"/> PROPANE <input type="checkbox"/> MAX INPUT(MBH) _____	
RATED F.L.A. _____	HIGH                      LOW	
ACTUAL F.L.A. _____	INLET GAS _____ <sup>W.C. off</sup> _____ <sup>W.C. run</sup> _____ <sup>W.C. run</sup>	
TRIAL FOR IGNITION _____ Sec.	MANIFOLD GAS _____ <sup>W.C.</sup> _____ <sup>W.C.</sup>	
IGNITION TYPE _____	BLOWER SPEED _____ RPM _____ RPM	
PRE PURGE _____ Sec.	NET STACK TEMPERATURE _____ F _____ F	
PROOF OF LOW FIRE START <input type="checkbox"/>	MAIN FLAME SIGNAL _____ V _____ V	
SAFETY LOOP WORKS PROPERLY <input type="checkbox"/>	BURNER MIXER POSITION _____	
OPER. TEMP SET POINT IS CONTROLLED	MEG VALVE CURRENT _____ (mA) _____ (mA)	
BY _____	PILOT GAS PRESSURE _____ <sup>W.C.</sup>	
SET POINT IS _____ F	PILOT FLAME SIGNAL _____ V	
OPERATIONAL TEMPERATURE IS SET ON _____ F	GAS ANALYZER PRINTOUT REPORT# _____ (Attached)	
DIFFERENTIAL IS SET ON _____ F	WATER INLET TEMP _____ F      WATER OUTLET TEMP _____ F	
HIGH TEMPERATURE LIMIT IS SET ON _____ F	APPROX STACK LENGTH _____ Ft (Horizontal) _____ Ft (Vertical)	
	DRAFT _____ <sup>W.C.</sup> (measured where stack exits boiler)	
	Total cycles                      Total hours                      (For 7800 series)	
<b>CONTROL/SAFETY DEVICES</b> <input type="checkbox"/> OK	<input type="checkbox"/> OK	<b>OTHER OPTIONAL DEVICES</b> <input type="checkbox"/> OK
HIGH TEMP. LIMIT <input type="checkbox"/>	AIR(AIR/GAS) PRESSURE SWITCH <input type="checkbox"/>	(LISTED) <input type="checkbox"/>
OPER. TEMP CONTROL <input type="checkbox"/>	BLOCKED VENT PRESS. SWITCH <input type="checkbox"/>	<input type="checkbox"/>
LOW WATER CUT OFF <input type="checkbox"/>	PRESSURE RELIEF VALVE <input type="checkbox"/>	<input type="checkbox"/>
FLOW SWITCH <input type="checkbox"/>	ALARM BELL <input type="checkbox"/>	<input type="checkbox"/>
LOW GAS PRESSURE SWITCH <input type="checkbox"/>	PRESSURE GAUGE <input type="checkbox"/>	<input type="checkbox"/>
HIGH GAS PRESSURE SWITCH <input type="checkbox"/>	<input type="checkbox"/>	<input type="checkbox"/>
<b>Mechanical Contractor:</b>	<u>TEL:</u> <u>DATE:</u>	<b>COMMENTS :</b>
Start up company:	<u>TEL:</u> <u>DATE:</u>	
Start up Technician:	<u>TEL:</u> <u>DATE:</u>	
Signature:	<u>TEL:</u> <u>DATE:</u>	

RETURN THIS REPORT TO GASMASTER IND. BY FAX (604) 574-9572