



Gasmaster Industries
Bldg #8, 15050 54A Ave.
Surrey V3S 5X7
CANADA

GMI 1.5M&1.5ML
1,500,000 Btu/hr Input
Gas-Fired Stainless Steel Boilers and Water Heaters

**INSTALLATION, OPERATION AND
MAINTENANCE MANUAL**

SERIAL NUMBER:
XXX.xx

GASMASTER DOCUMENTS

DESCRIPTON	SECTION
Performance & Structural Test Report	1
Q/C Department Release Report	1
Installation, Operation, & Maintenance Manual	2

DRAWINGS

NUMBER	DESCRIPTION	SECTION
1	Heat Exchanger Schematic	2
2	Control System Schematic	3
3	Gas Line	3
4	Inlet Manifold Assembly	3
5	Front View/ Dimensions	3
6	Side View/Dimensions	3
7	Top View/Dimensions	3

COMPONENTS' DOCUMENTS

MANUFACTURER	COMPONENT	SECTION
Riello	Catalogue	4
Honeywell and Siemens	Main Gas Valves	5
ASCO	Pilot Gas Valves	6
Siemens	Temperature Controller	7
Honeywell	High Temperature Limit	8
McDonnell & Miller	Low Water Cut Off Switch	9
Conbraco	Safety Relief Valve	11
Antunes/Dungs Controls	Air Pressure Switch	12
Honeywell	Gas Pressure Switch	13
LFL	Gas Burner Controls	14
Siemens	Reversing Actuator	15
Maxitrol	Pressure Regulators	16

List of Contents

Title	Page
GMI 1.5M SPECIFICATIONS AND DIMENSIONS	4
SECTION 1: INTRODUCTIONS	
1.1 Boiler Description	6
1.2 Control System	7
1.3 Safety Features	7
1.4 Gas Line	8
1.5 Gas Manifold and Control Assembly	10
1.6 Code Compliance	10
1.7 Freeze Protection	11
1.8 Water Treatment	11
SECTION 2: INSTALLATION	
2.1 Boiler/Water Heater Package	13
2.2 Location	14
2.3 Relief Valve	14
2.4 Water Connection	15
2.5 Condensate Line	15
2.6 Gas Line Connection	15
2.7 Vent Connection	16
2.8 General Instruction	19
SECTION 3: OPERATION	
3.1 Sequence of Operation	22
3.1.1 Safety Loop	22
A: Components	22
B: Sequence of Events	23
3.1.2 Pre-Purge	23
3.1.3 Main Flame	24
3.1.4 Operation	24
3.2 Pre Commissioning	25
3.3 Commissioning	27
3.4 General Instruction	29
SECTION 4: MAINTENANCE	
4.1 Service Hint	31
4.2 Troubleshooting	32

GMI 1.5M SPECIFICATIONS AND DIMENSIONS

CGA/AGA Input	Btu/h	1,500,000
CGA/AGA Output	Btu/hr	1,425,000 (as hot water boiler, tested in accordance with ANSI Z21.13)
	Btu/hr	1,470,000 (as water heater, tested in accordance with ANSI Z21.10.3)
Boiler Efficiency @ full load	%	95.0
Water Heater Efficiency @ full load	%	98.8
Fuel		Natural Gas
Electrical Rating	V/PH	208,230,60, three phase, less than 12 amps
Heating surface	Ft ²	208.79
Boiler Shell Dimensions		
- Width	Inches	64 .25
- Depth	Inches	25.75
- Height	Inches	69.75
Overall Dimensions		
- Width	Inches	64.25
- Depth	Inches	53.75
- Height	Inches	89.25
Shipping Weight	Lbs	1425
Supply/Return Connections	Inches	3 FLG
Gas connection	Inches	1.5 NPTF
Gas inlet pressure	Inches WC	7 to 14
Flue connection	Inches	8 - 16
Flue duct material		Stainless Steel (air tight, corrosion resistant)
Air supply connection	Inches	N/A
Maximum working pressure	psig	160
Maximum working temperature	Degrees F	210
Minimum inlet water temperature		Any temperature above freezing
Minimum water flow rate	USG/min	18
Minimum service clearance	Inches	Top 40, Front 40, Back 10, Floor 0
Minimum clearances to combustibles	Inches	Top 40, Front 40, Back 2, Opposite Burner Side 2, Burner Side 24, Floor non-combustible

Note: Installation of a flow switch on the inlet header is strongly recommended.

GMI 1.5ML SPECIFICATIONS AND DIMENSIONS

CGA/AGA Input	Btu/h	1,500,000
CGA/AGA Output	Btu/hr	1,425,000 (as hot water boiler, tested in accordance with ANSI Z21.13)
	Btu/hr	1,470,000 (as water heater, tested in accordance with ANSI Z21.10.3)
Boiler Efficiency @ full load	%	95.0
Water Heater Efficiency @ full load	%	98.8
Fuel		Natural Gas
Electrical Rating	V/PH	120, single phase, less than 12 amps
Heating surface	Ft ²	194.39
Boiler Shell Dimensions		
- Width	Inches	64
- Depth	Inches	25
- Height	Inches	69
Overall Dimensions		
- Width	Inches	66
- Depth	Inches	62.5
- Height	Inches	88.5
Shipping Weight	Lbs	1425
Supply/Return Connections	Inches	3 NPT male
Gas connection	Inches	1.5 NPTF
Gas inlet pressure	Inches WC	7 to 14
Flue connection	Inches	8 - 16
Flue duct material		Stainless Steel (air tight, corrosion resistant)
Air supply connection	Inches	N/A
Maximum working pressure	psig	160
Maximum working temperature	Degrees F	210
Minimum inlet water temperature		Any temperature above freezing
Minimum water flow rate	USG/min	25
Minimum service clearance	Inches	Top 40, Front 40, Back 10, Floor 0
Minimum clearances to combustibles	Inches	Top 40, Front 40, Back 2, Opposite Burner Side 2, Burner Side 24, Floor non-combustible

SECTION 1:
INTRODUCTION

1.1 Boiler/Water Heater Description

The Gasmaster GMI 1.5M series are gas-fired boilers and water heaters with nominal input rating of 1,500,000 Btu/hr. Each unit consists of two stainless SA312, Type 304, ND10 3/4" schedule 140 machined (grooved) central hubs. Coiled around each hub is a 1 1/4" SS tube type 316L with minimum wall thickness of 0.065". In between the two coils there are two 316L stainless steel middle coils without the central hub (please see Figure 1, below). All four coils are held parallel in a vertical plane, at a predetermined distance, by means of four SS spacers/ready rods and adjustment nut assemblies placed between four tabs welded to the perimeter of each coil. The inlets and outlets of all four coils are connected to 3" schedule 40 stainless steel pipe, ASME SA-312, Type 316/316L inlet and outlet manifolds, respectively. Therefore, there are only one inlet and one outlet connections to the building's return and supply lines. The volume contained between the central parts of the coils defines the combustion chamber of the boiler/water heater. The volume contained between the remaining sections of the coils represent the "tail pipe" section of the unit. Water enters each coil at the perimeter and exits at the center (near the central hubs), thus allowing for a counter flow heat exchange process.

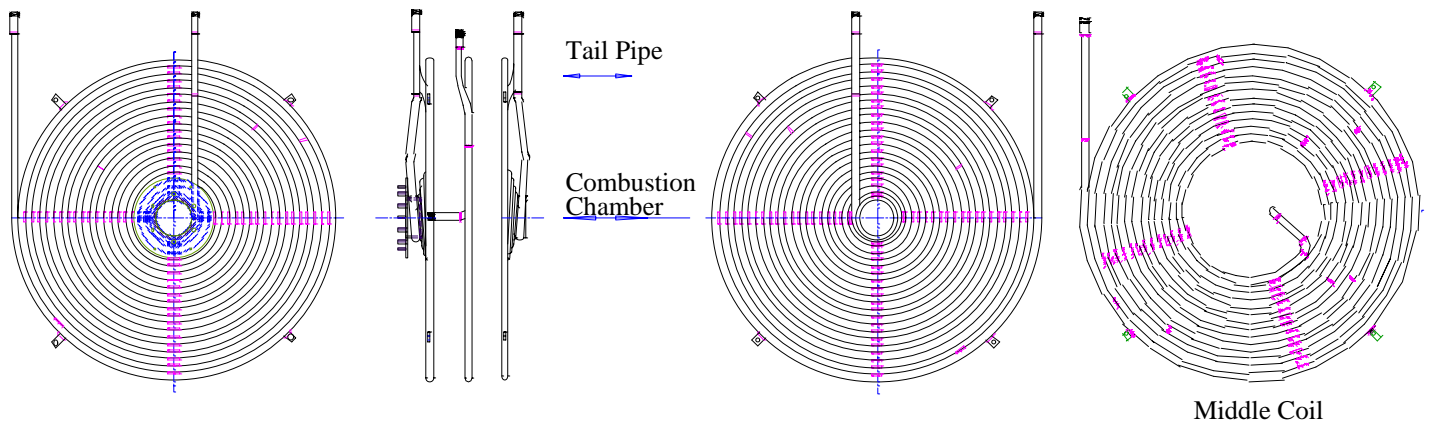

Figure 1: Heat Exchanger Configuration

Four stainless steel ready rods (running through the tabs) connect the coils to the side legs of the housing. The unit's housing (casing) comprises inside and outside panels constructed from 14 and 18 gauge stainless steel plates, respectively. The unit's base panel is constructed from 14 gauge stainless steel plates. Two-inch fiberglass insulation is sandwiched between the inner and outer panels. Combustion products exit the housing through an 8" – 16" diameter exhaust outlet at the top corner of the front panel. A catch tray is secured to the base of the housing for collection of the condensate. The condensate exits the housing through a "U" shaped outlet trap near the bottom of one of the side panels.

Air and gas mixture enters the combustion chamber through a Riello burner nozzle. The boiler/water heater utilizes turbulent combustion technology that allows for compact sized combustion chamber, high efficiency, and low NOx operation. Heat transfer from combustion flame to water takes place in a turbulent mode. In addition, water flow through the coils is also of high speed and turbulent mode. Furthermore, unlike conventional boilers and water heaters where heat transfer from hot combustion gases to water takes place in a "natural convection" mode, the flame and combustion gases in Gasmaster products directly "impact" on the surface of coils,

transferring heat through conduction and “forced convection”. Finally, heat is transferred through a “counter flow” process. That is, at any given point along the surface of heat exchanger, maximum temperature difference is achieved between water and flame/combustion gases. These factors result in a highly efficient process for transfer of heat energy from combustion flame and exhaust gases to water.

1.2 Control System

The boiler/water heater control module consists of an “Individual Boiler/Water Heater Control Module”, or the “BMS” (Boiler Management System) signal input module as an option.

With the “Individual Boiler/Water Heater Control Module”, the unit’s operation is governed by the desired outlet (hot water) temperature. Using a digital, high precision temperature controller, the owner will identify the required hot water temperature. A temperature sensor installed on the boiler/water heater outlet manifold continuously measures the outlet water temperature. A servomotor controlling the gas butterfly valve and the air damper (by means of a variable profile cam mechanism) allows for throttling of the air/gas mixture flowing into the Riello burner. For as long as the set temperature is above that of the outlet water, the boiler/water heater operates at maximum output capacity. Analogue 2 – 10 VDC output signal from the temperature sensor are sent to the temperature controller, which in turn sends corresponding signals to the servomotor. This throttles the flow of gas and combustion air in the gas butterfly valve and the air damper. Therefore, the appropriate volume of air/gas mixture flows into the burner, allowing for almost perfect air/gas mass, and volume ratios. As the outlet temperature approaches the set temperature, the air/gas mixture flow is gradually reduced by the servomotor (connected to the gas butterfly valve and the air damper). This results in the corresponding gradual decrease in the unit’s capacity. Thus the throttle system allows for optimum continuous operation of the boiler, significantly reducing on/off cycles. The said system offers the user almost infinite modulating capacity within the boiler/water heater operating range.

1.3 Safety Features

Each Gasmaster GMI 1.5M boiler and water heater is equipped with a number of safety features.

- I: Low Water Cut Off Switch:*** One “McDonnell & Miller” low water cut off switch is installed on the outlet manifold. When water reaches the LWCO position, the burner should fire.

- II: Flame Sensor:*** A Riello flame probe is used as a flame proving sensor. This is connected to the burner controller, and is installed inside the burner head. At any time after the main gas valve is opened, if flame is not detected for a period longer than 2.5 seconds, the burner controller will be deactivated and the main gas valve will immediately close.

- III: High Temperature Limit:*** Each unit is equipped with a “Honeywell” high temperature limit switch. If outlet water temperature exceeds the temperature set on this switch, the burner controller will be deactivated and the gas valve will immediately close.

- IV: Air Pressure Switches:** One Riello low air pressure switch is installed on the side of the blower and measures air pressure entering the burner (for exact location of the switch please see item #5 on the drawing presented on page 4 of the Riello catalogue). If the combustion air pressure drops by more than 20% below the nominal air pressure (minimum pressure of 0.4" wc), the burner controller will be deactivated and the main gas valve will immediately close. The Antunes Controls air pressure switch is installed on the side panel of the unit's housing. If pressure inside the housing is increased above 0.3", the burner controller will be deactivated and the main gas valve will immediately close.
- V: Relief Valve:** A "Conbraco" safety relief valve with prescribed nominal pipe size of 1 1/4" valve inlet/outlet, and minimum relief capacity of 4,974,000 Btu/hr and 150 psig relief pressure, is installed on the water outlet manifold and supplied as standard equipment. When the boiler or water heater is used in heating applications having working pressures in the range 40–160 psig, an appropriate pressure relief valve should be installed.
- VI: Gas Pressure Switch:** One Honeywell manual reset low gas pressure switch is installed on the gas train in between the gas pressure regulator and the first safety shut off valve (please see the schematic diagram "Typical UL Schematic Gas Piping" on page 9 of the Riello catalogue). If the line pressure drops below 7" wc, the switch will open and the unit will immediately shut down.

1.4 Gas Lines

1.4.1 Pilot Gas Line

Referring to the "Typical UL Schematic Gas Piping" diagram on page 9 of the Riello catalogue, gas from the main supply line flows at the maximum pressure of 14" wc through the manual valve into the pilot line. From the pressure regulator it will then flow through the two safety shut off valves into the burner. The pressure regulator is adjusted such that gas flows within 2" – 5" wc pressure into the first safety shut off valve. If pilot flame is not established within 5 seconds of the ignition trial time, the flame safeguard will shut off the pilot safety gas valves.

The pilot flame will ignite the air/gas mixture flowing through the burner within 5 seconds of the mixture flowing into the burner.

1.4.2 Main Gas Line

Referring to the same drawing, gas from the main supply line flows at a maximum pressure of 14" wc through the manual gas valve into the main gas line. From the pressure regulator it will then flow through the two safety shut off valves, into the second manual shut off valve. Finally gas flows through the gas adjustment butterfly valve into the burner where it is ignited by the pilot flame. The pressure regulator is adjusted such that the manifold gas pressure remains within 0.2 – 3.0" wc. This pressure is tested at the manifold gas pressure test point located on the side of the

Riello burner (for exact location of the test point please see item #8 on the drawing presented on page 4 of Riello catalogue). Signals from the temperature controller are sent to the servomotor, which controls the opening of the butterfly valve and the air damper. Subsequently, the valve and damper are proportionately closed or opened in order to decrease or increase the air/gas mixture flow into the burner. Hence, maintaining the outlet water at constant temperature, during changes in the load/demand (i.e. throttle or load tracking function).

NOTES

- *Air and gas flow rates are factory adjusted for optimum combustion quality. Note that these settings may vary slightly at different site conditions (calorific value of gas, duct length, etc.).*
- *After installation is completed, using a gas analyzer, the CO and O₂ contents of the exhaust gases should be re-checked to ensure their compliance with those achieved at the factory and reflected in the test report provided to your local Gasmaster representative.*
- *IF adjustments to the factory settings of air and gas flows are made, ensure that the manifold gas pressure does not exceed the 3.0" wc specified by the burner manufacturer.*

WARNING

Exceeding the maximum allowable gas manifold pressure could result in over-firing of the unit and may cause permanent damage to the unit.

1.5 Gas Manifold and Control Assembly Tests

Safe operation and all performance criteria of all Gasmaster products, incorporating the installed gas manifold and control assembly, are proven before delivery when the products are factory tested in accordance with the ANSI Z21.13b 2000 standards.

1.6 Code Compliance

In Canada, boiler installation must conform to the requirements identified in the CGA Codes CAN1-B149-1 or CAN1-B149-2 for gas burning appliances, CSA Codes B51 for boiler, pressure vessel, and pressure piping, and/or all applicable local codes. All electrical connections are to be made in accordance with the requirements of CSA C22.1, Canadian Electrical Code, Pat 1, and/or all applicable local codes.

In the United States of America, the installation must conform to the requirements of the authority having jurisdiction or, in the absence of such requirements, to the National Fuel Gas Code, ANSI Z223.1-latest edition. All electrical wiring must be carried out in accordance with the National Electrical Code ANSI/NFPA No.70-latest edition, and any additional state or local code requirements. If an external power source is used, the unit must be electrically grounded in accordance with the requirements of the authority having jurisdiction. In the absence of such authority, the boiler must be electrically grounded in accordance with the National Electrical Code ANSI/NFPA No. 70-latest edition.

The plumbing and condensate disposal must be carried out in accordance with the local plumbing codes.

NOTES

- *Boiler/water heater can be used in both closed loop and open loop (one pass) operations.*
- *In the commonwealth of Massachusetts the installation shall be carried out by a licensed gas fitter/plumber and comply with 48CMR*

1.7 Freeze Protection

- When used in an open or closed loop configuration, whenever necessary, the boiler or water heater must be drained. Due to the radial geometry of the unit, it must be drained by forced air only.
- When used in a closed loop configuration, if absolutely necessary, system antifreeze can be utilized, in which case the boiler or water heater does not need to be drained. The antifreeze must be compatible with hydronic heating systems.

1.8 Water Treatment

All heat exchanger coils are constructed from high grade stainless steel. Therefore, high oxygen content in the feed water should not result in any corrosion inside the coils. Since water flow through coils is in turbulent mode, and they are continuously expanding and contracting; the operation of the unit is to a large extent self cleaning. Therefore, other potential minerals that may exist in water should not have any adverse effect (on the tubes). However, if it is wished to supply soft water to the boiler or water heater, then a sodium-based ion-exchanger may be used. Note that “soft water” is defined as one having less than 0.12° British, or 0.17° US hardness level. Consult a local water treatment consultant to determine if water treatment is required.

SECTION 2:
INSTALLATION

2.1 Boiler/Water Heater Package

Each unit is supplied with:

1. Riello burner/blower.
2. Inlet and outlet manifolds.
3. High temperature cut off switch with manual reset.
4. Operating temperature switch.
5. Pressure relief valve.
6. Main gas valve.
7. Fully assembled gas piping.
8. One low water cut off switch installed on the outlet manifold.
9. Two air pressure switches
10. One gas pressure switch.
11. One Temperature sensor installed on the outlet manifold and connected to the control burner.
12. Flame Rod
13. Flame sensor
14. Condensate drain connection.
15. Flue gas connection.
16. Pressure/temperature gauge.
17. One purge valve installed at the inlet of each coil.

2.2 Location

- I:** This boiler/water heater is for indoor installation only.
- II:** For service access to the Riello control box, condensate drain “U” trap, and gas train, refer to the clearances indicated on the boiler/water heater rating plate. Note that some jurisdictions may have their own clearance requirements. In such cases refer to all applicable local codes.
- III:** The boiler/water heater can be placed in a basement or utility room. It should not be placed in an unconditioned area where the unit and condensation could be subject to freezing temperatures.
- IV:** For reduced installation cost, locate the boiler/water heater as close to an outside wall as possible.
- V:** Flue gases can be vented out directly through a wall, or in case of retrofit installation, the flue gas duct can be extended into the existing chimney.
- VI:** Keep boiler/water heater area clear and free from combustible materials, gasoline, flammable vapors and liquids.
- VII:** Ensure that inlet to the blower is kept clear of any obstruction so that combustion air can flow freely through to the air intake blower.
- VIII:** A resilient pad to separate the boiler/water heater from floor IS NOT REQUIRED.

2.3 Relief Valve

A pressure relief valve is supplied as standard equipment. The relief valve is extra protection against damage that could be caused by excessive water pressure. Either, mal-functioning of controls, or creation of steam pockets due to water stagnation in some parts of the coils, may cause such excessive pressure. This latter condition could arise if one or both coils are not properly purged.

The pressure relief valve should be connected to a suitable water drain. The drain pipe **MUST** pitch down from the valve and its internal diameter should not be less than that of the relief valve. The end of the drain line should not cause any restriction to the water flow, and should be protected from freezing. There should not be any valve of any type installed between the pressure relief valve and the end of the drain line. Similarly, there should not be any instrument installed anywhere along the length of the drain valve, between the relief valve and the end of the drain line. The relief valve is installed in vertical position and should remain in that position at all times.

2.4 Water Connection

All pre-installation work has been completed at the factory. Two water manifolds (inlet and outlet headers) are provided with the unit. One low water cut off switch is installed on the outlet manifold. One high temperature limit switch, and one pressure relief valve are installed on the outlet manifold. A thermocouple installed on the outlet manifold is connected to the appropriate terminals in the Riello control box. Installation of a flow switch on the inlet header is strongly recommended.

Cold-water inlet and hot water outlet connections are clearly marked on the respective manifolds of the boiler/water heater. The cold water supply line (in one pass applications), or return water (in closed loop applications) should be connected to the cold water inlet of the unit. The hot water supply line should be connected to the hot water outlet of the boiler. Both manifolds have 3" stainless steel flange, ANSI 150 lbs inlet/outlet connections.

For further information on methods of connecting supply and return water piping to boilers/water heaters consult available installation and piping guides developed according to local plumbing codes.

2.5 Condensate Line

Connect 3/4" ABS tubing from the condensate drain "U" trap, directly to the floor drain. Notice that the line MUST be pitched downward towards the floor drain to avoid traps. DO NOT install any valve of any type, or any other instrument between the condensate drain "U" trap and the end of the condensate line.

NOTE

- *To ensure proper flow of condensate, it is recommended to install a "drain vent" of approximately 1 foot height at 0.5-1 foot downstream of the U trap.*

2.6 Gas Line Connections

The gas train comprises a pressure regulator, low gas pressure switch, solenoid valve, and the main gas valve. Gas pressure at the inlet to the pressure regulator should always remain in the 7" – 14" wc range. If higher pressures are present, consult the local gas company or gas installation codes for installing the appropriate gas pressure regulator. Gas line from the meter to the boiler/water heater should be of adequate size to prevent undue pressure drop. A manual shut off valve should be installed in the gas line upstream of the pressure regulator, so that the control instruments (main gas valve, boiler/water heater gas regulator, and low gas pressure switch) could be easily isolated and removed, whenever necessary. The valve should be clearly marked, located outside the unit's

housing, readily visible and accessible for turning on and off. If the unit is to be installed in, under, or directly attached to a pool, or spa, structure, the said manual valve should be located outside the structure.

NOTE

- *Inlet gas pressure upstream of the unit must always remain within the 7" – 14" wc range.*

2.7 Vent Connection

Connect an 8" - 16" ID vent (size is optional) to the exhaust gas outlet at the right hand bottom corner of the front panel. The combustion gases can be exhausted either directly through the wall, or through a chimney (in case of retrofit applications). If venting directly through a wall, allow at least a 5% rising slope of horizontal duct immediately after the exhaust outlet on the boiler. Maximum allowable equivalent length of duct (between boiler and wall) is 60' for 16" ID duct and 27' for 8" ID duct.

If due to installation, or site limitations, sufficient vertical height cannot be made available, an exhaust fan, power vent, or draft inducer should be used to vent the exhaust gases.

Information on the suitable model number for the desired equivalent length can be obtained from the product's manufacturer (e.g. Dayton or Fields Control).

Equivalent Lengths

90 deg. Elbow	3'
45 deg. Elbow	2'
Condensate Tee	2'
Vent Cap	3'

NOTES

- *The exhaust venting system must meet the requirements of category IV boilers (i.e. corrosion resistant, water and air-tight).*
- *The exhaust duct outlet to the atmosphere MUST be wind protected by an approved wind cap.*

2.7.1

When an existing boiler or water heater is removed from a common venting system, the common venting system is likely to be too large for proper venting of the appliances remaining connected to it. Therefore:

At the time of removal of an existing boiler or water heater, the following steps should be followed with each appliance remaining connected to the common venting system placed in operation, while the other appliances remaining connected to the common venting system are not in operation

- I:** Seal any unused openings in the common venting system.
- II:** Visually inspect the venting system for proper size and horizontal pitch and determine there is no blockages, restrictions, leakage, corrosion or other deficiencies, which could cause an unsafe connection.
- III:** Insofar as is practical, close all building doors and windows and all openings between the space in which the appliances remaining connected to the common venting system are located and other spaces of the building. Turn on the clothes dryers and any appliance not connected to the common venting system. Turn on any exhaust fans, such as range hoods and bathroom exhausts, so they will operate at maximum speed. Do not operate a summer exhaust fan and close fireplace dampers.
- IV:** Place in operation the appliance being inspected. Follow the lighting instructions; adjust the thermostat so the appliance will operate continuously.
- V:** Test for spillage at the draft hood relief opening after 5 minutes of main burner operation. Use the flame of a match, candle, or smoke from a cigarette, cigar or pipe.
- VI:** After it has been determined that each appliance remaining connected to the common venting system properly vents, when tested as outlined above, return doors, windows, exhaust fans, fireplace dampers and any other gas-burning appliance to their previous condition of use.
- VII:** Any improper operation of the common venting system should be corrected, so the installation conforms to the National Fuel Gas Code, ANSI Z223.1. When resizing any portion of the common venting system, the common venting system should be resized to approach the minimum size as determined using the appropriate tables in Appendix G in the National Fuel Gas Code, ANSI Z223.1”.

2.7.2

For connection to gas vents or chimneys, vent installations should be in accordance with Part 7, Venting of Equipment, of the National Fuel Gas Code, ANSI Z223.1, or applicable provisions of the local building codes.

Vent connectors serving appliances vented by natural draft should not be connected into any portion of mechanical draft systems operating under positive pressure.

The horizontal portions of the venting system should be supported to prevent sagging. The methods of and intervals for support should be in accordance with the local code standards. Furthermore, the following installation requirements should also be satisfied:

- I:* Horizontal runs should slope upwards not less than 1/4" per foot (21 mm/m) from the boiler to the vent terminal.
- II:* The vent system should be installed to prevent accumulation of condensate.
- III:* Where necessary, the vent system must provide the means for drainage of condensate.

2.7.3

Vent termination should be in accordance with all applicable local codes. In addition, the following conditions must be satisfied:

- I:* Distances from adjacent public walkways, buildings, windows and building openings, should be consistent with the National Fuel Gas Code, ANSI Z223.1.
- II:* Minimum clearance of 4 feet (1.22 m) horizontally and in no case above or below, unless a 4-foot (1.22 m) horizontal distance is maintained from electric meters, gas meters, regulators and relief equipment.

2.7.4

It is recommended to install prefabricated factory-made vent parts each designed to be assembled with the other without requiring field fabrication.

MANUFACTURER	VENT PART MODEL	MATERIAL
Heat-Fab Inc.	Saf-T Vent system	Stainless Steel

2.8 General Instructions

2.8.1

The boiler/water heater and its individual shutoff valve must be disconnected from the gas supply piping system during any pressure testing of that system, at test pressures in excess of 0.5 psig. The unit must be isolated from the gas supply piping system by closing its individual manual shutoff valve, during any pressure testing of the gas supply piping system at test pressures equal or less than 0.5 psig.

2.8.2

The boiler/water heater should be installed such that the gas ignition system components are protected from water (dripping, spraying, rain, etc.) during appliance operation or service.

2.8.3

The boiler/water heater and its gas connection must be leak tested, before placing the boiler in operation.

2.8.4

The boiler/water heater when installed must be electrically grounded and bonded in accordance with the local codes or in the absence of such codes, in accordance with the National Electrical Code, ANSI/NFPA 70.

2.8.5

The boiler/water heater should be located in an area where leakage of the tank, or connections, will not result in damage to the area adjacent to the appliance or to the structure. When such locations cannot be avoided, it is recommended that a suitable drain pan, that drains adequately be installed under the boiler. The pan must not restrict air- flow.

2.8.6

When a heater is installed within a pool structure, the structure should be designed so that in the event of a fuel gas leak, the leaking gas is vented to the exterior of the pool structure.

2.8.7

For proper operation of a spa or hot tub the following safety rules should be observed:

- Spa or hot tub water temperature should never exceed 104° F (40° C). A temperature of 100° F (38° C) is considered safe for an adult. Special caution is suggested for young children.
- Drinking alcoholic beverages before or during hot tub or spa use can cause drowsiness, which could lead to unconsciousness and subsequently resulting in drowning.
- Pregnant women should be cautious. Soaking in water above 102° F (39° C) can cause fetal damage during the first three months of pregnancy. Pregnant women should respect the 100° F (38° C) maximum rule.
- Before entering the spa or hot tub, the water temperature should be checked with an accurate thermometer. Spa or hot tub thermostats may have an inaccuracy, as high as 4° F in regulating the water temperature.
- Persons with medical history of heart disease, circulatory problems, diabetes or blood pressure should obtain their physician's advice before using spas or hot tubs.
- Persons taking medications, which induce drowsiness should not use spas or hot tubs.

SECTION 3:
OPERATION

3.1 Sequence of Operation

3.1.1 Safety Loop

A: Components

Referring to Figure 2 (Control System Schematic) the safety loop includes the following components:

- I: High temperature cut off switch:** This is a manually reset switch and is normally closed. It is installed on the outlet manifold. The desired high limit temperature is set by the owner and is usually 10 °F above the maximum operating (alarm) temperature. In no event should this switch be set at above 210 °F. If the outlet temperature increases above the set temperature, this switch will open and the unit will go into the “lock-out” mode. The unit will remain in this mode until the operator manually resets the switch.
- II: Maximum operating (alarm) temperature switch:** This switch is normally closed and is embedded in the Siemens temperature unit. The maximum operating temperature should be set on this display. The desired outlet temperature (desired set point) is also set by the owner on the same Siemens temperature controller.
- III: Low water cut off switch:** One low water cut off is installed in the end of manifold. The switch is normally open, and as soon as water level in the system reaches the point where the switch is installed, it will close.
- IV: Remote Enable/Disable Terminals:** There are “Remote Enable/Disable” terminals in the control panel. These terminals can be used for the BMS connections, if required.
- V: Low gas pressure switch:** A Honeywell manual reset low gas pressure switch is installed on the gas train between the gas pressure regulator and the first safety shut off valve (please see item #4 on the schematic diagram “Typical UL Schematic Gas Piping” on page 9 of the Riello catalogue). If the line pressure drops below 7” wc, the switch will open and the unit will immediately shut down.
- VI: Air Pressure Switches:** One Riello low air pressure switch is installed on the side of the blower and measures air pressure entering the burner (for exact location of the switch please see item #14 on the drawing presented on page 4 of the Riello catalogue). If the combustion air pressure drops by more than 20% below the nominal air pressure (minimum pressure of 0.4” wc), the burner controller will be deactivated and the main gas valve will immediately close. The Antunes Controls air pressure switch is installed on the side panel of the unit’s housing. If pressure inside the housing is increased above 0.3”, the burner controller will be deactivated and the main gas valve will immediately close.

WARNING

Do not bypass any of the instruments in the safety loop. Doing so may cause serious damage to the unit and its surroundings.

B: Sequence of Events

- I:** Every boiler/water heater is fully tested at the factory prior to shipment (please see test report and Q/C release form in section 1). When the unit is tested at the factory, a “jumper” is placed between terminals identified as “Remote Enable/Disable” (see Figure 2). If BMS is used, this jumper should be replaced by wires from the BMS. In the absence of a BMS, the operation of the unit is governed by the Siemens temperature controller.
- II:** Once the blower starts operating, the Riello air pressure switch will close. This switch has been factory adjusted such that when the blower reaches its minimum frequency it will close.

3.1.2 Pre-Purge

- I:** When the Riello air pressure switch is closed and safety loop is satisfied, pre-purge will start.
- II:** Blower continues to run at its maximum frequency for a period of 37.5 seconds

3.1.3 Pilot Flame

- I:** After completion of the pre-purge period, the burner controller sends the required high voltage to the ignition rod, and 120V to the two pilot safety shut off valves. The valves open simultaneously with the activation of the ignition rod. Upon pilot ignition, and after the flame is detected by the sensor, the ignition rod will be deactivated.
- II:** If after 5 seconds activation of the flame rod and opening of the gas valves, pilot flame is not established and detected by the flame sensor, the gas valves will immediately shut down and the boiler/water heater goes into the “lock-out” mode. The unit will not re-start until the burner controller is manually reset.

3.1.4 Main Flame

- I:*** Once pilot flame is established burner controller will send 120V to the two main safety shut off valves. From these valves gas flows into the gas butterfly valve (see schematic diagram on page 9 of the Riello catalogue).
- II:*** Air supplied by the blower flows through to the burner head where it mixes with gas and the air/gas mixture is ignited by the flame rod.
- III:*** The pilot safety shut of valves will close five seconds after the main safety valves are opened. If at any time during the operation flame (pilot or main) is not detected the boiler/water heater will immediately shut down and will not restart until the burner controller is manually reset.

3.1.5 Operation

The unit continues to operate at low fire for as long as the outlet (discharge) temperature remains higher than the desired temperature, and lower than the maximum operating (alarm) temperature; both being set on the Siemens temperature controller. The thermocouple installed on the outlet manifold continuously measures the discharge water temperature. Signals from this thermocouple are sent to the Siemens temperature controller. If the temperature measured by the thermocouple is below that of the desired temperature, corresponding signals are sent to the servomotor. This will open the gas butterfly valve and air damper proportionately, thereby increasing the input capacity of the unit to its maximum value at high fire. As soon as the discharge water reaches the desired temperature (set on the Siemens controller by the owner), the process is reversed and the input is decreased so that discharge water remains at constant temperature. This throttle (load tracking) process continuously takes place through increase or decrease in the air/gas mixture (opening/closing of the butterfly valve and air damper), thereby ensuring water is always supplied at ± 1 °C of the desired operating (discharge) temperature.

If the water temperature reaches the maximum operating (alarm) set point, the boiler/water heater will shut down and goes into the stand by mode. The unit will automatically re-start when the water temperature drops below the operating set point minus the differential temperature.

NOTE

- *If as a result of mal-functioning of the temperature controller the discharge water temperature increases above that of the high limit temperature switch, the unit will automatically shut down and will not re-start until said switch is manually re-set.*

3.2 PRE-COMMISSIONING

I: Water connections (Return and Supply Lines)

- Purge air from the piping system, and from the boiler/water heater.
To purge the unit, close 3 of the 4 purge valves and run water through the open coil for at least five minutes. The coil is now completely purged. Repeat the process for the remaining 3 coils, until all 4 coils are completely purged.

II: Gas Connections

- All pipe connections should be carried out in strict compliance with all applicable local codes.
- Selection of the gas regulator model and size should be carried out in accordance with the design requirements.
- Conduct a complete leak test on the unit's gas train, and all gas lines connected to it.
- Measure the static pressure upstream of the unit to ensure it is within the prescribed range of 7" - 14" wc.

III: Vent Connection

- Installation must be carried out in accordance to all applicable local codes and factory guidelines.
- When required, a proper drain should be installed on the vent.

IV: Condensate Line Connection

- Inspect the condensate line and ensure it is installed in accordance with the factory guidelines.
-

V: *Power Connection*

- Inspect all wiring connections to the unit and ensure they comply with all applicable local codes.
- Ensure that the appropriate power supply has been connected to the unit (please refer to the electrical rating on the unit's nameplate).
- Ensure the temporary jumpers have been removed from the unit's control panel.
- If applicable, ensure the external control connections have been wired.

WARNING

Ensure the manual gas valve is closed prior to power being supplied to the boiler/water heater

NOTE

- *Start-up and commissioning MUST be carried out by a GMI qualified technician.*

WARNING

The field start-up report MUST be faxed to GMI at 604-574-9572 within 10 days of start-up. Failure to do so will result in cancellation of all expressed and/or implied warranties.

3.3 Commissioning

- I:** Purge heat exchanger coils in accordance with the procedure outlined in paragraph **I** of section 3.2.
- II:** Measure flow rate through the unit to ensure a minimum of 18 GPM is available through the unit.
- III:** Connect (plug in) the power supply cord to the 120V wall outlet. Turn the “ON/OFF” switch (located on the front panel of the Riello blower/burner assembly) to the “ON” position.
- IV:** After the system has undergone the sequence of events described in Section 3.1 above and when the two safety shut off valves in the main gas line are opened, the unit will be in regular operating mode.
- V:** The Antunes air pressure switch installed on the side panel of the unit has been factory set at 0.3” wc. With the unit in operation, measure the exhaust gas pressure inside the housing at the “T” connection located under the pressure switch.

VI: Test Points

- Measure gas line pressure upstream of the gas pressure regulator to ensure it is within the specified range of 7” – 14” wc.
- Measure the gas manifold pressure at the test point located adjacent to the burner’s gas inlet connection port (for exact location please see item #8 on page 4 of the the Riello catalogue), ensure it is within the specified 0.2” –3.0” wc.
- Measure the manifold air pressure at the test point located on the side of the burner (please see item #7 on page 4 of the Riello catalogue). Ensure this pressure is between 0.4” – 1.4” wc.

WARNING

The gas manifold pressure should not exceed the maximum value shown on the unit’s nameplate.

3.4 GENERAL INSTRUCTIONS

- I:*** Should overheating occur or the gas supply valve fails to shut off, do not turn off or disconnect the electrical supply to the pump. Instead, shut off the gas supply at a location external to the unit.

- II:*** **Do not use this boiler/water heater if any part has been under water.** Immediately call a qualified service technician to inspect the boiler/water heater and to replace any part of the control system or any gas control component, which has been under water.

SECTION 4:
MAINTENANCE

4.1 Service Hints

- I:** Gasmaster boilers and water heaters have been designed and developed based on a unique patented technology. When operated properly, the products will provide the owner with years of trouble free performance. To benefit for many years, from the unique performance characteristics of these boilers and water heaters, it is recommended to have your boiler/water heater inspected by a qualified service person at least once every year.
- II:** Ensure that air intake and exhaust ducts are always free of any debris and restrictions. This will allow the electric motor to operate under normal loads, as well as allowing for a clean combustion process. Do not store anything against the boiler and ensure that the boiler is kept in a clean environment. Do not store any combustible material, flammable liquid, or vapor, in the vicinity of the boiler.
- III:** Should overheating occur or the gas supply fails to shut off, turn off the manual gas control valve.
- IV:** Label all wires prior to disconnection when servicing the controls. Wiring errors can cause improper and dangerous operation.
- V:** Verify proper operation after each service (refer to the start-up report).
- VI:** The following precautions should be taken at least once a year:
- Check the condensate drain line (including the “U” trap) to ensure there is no restriction in the line.
 - Check the duct and draft hood to ensure there is no restrictions or signs of rust. Ask your service person to clean the duct and the draft hood, if required.
 - Inspect the sheet metal covering the insulation for any sign of rust or corrosion. If necessary, contact your service person to clean the sheet metal panels.
 - Inspect all flue gas passageways, including the inner surface of the heat exchanger for any sign of rust or corrosion. If necessary, contact your service person to clean the surfaces.
 - Inspect the central plate and the burner for any sign of damage or corrosion. Contact your service person for cleaning the surfaces or replacement of the component, if necessary.

4.2 Troubleshooting

Fault	Cause	Corrective Action
<ul style="list-style-type: none"> ◆ Blower does not start 	<ul style="list-style-type: none"> ◆ Power not supplied to the unit. ◆ Safety loop open. ◆ None of the above 	<ul style="list-style-type: none"> ◆ Ensure power switch is on. ◆ Check both fuses on the power and the supply sides. ◆ Ensure BMS (if connected) calls for heat. ◆ Ensure high temperature limit switch is closed. ◆ Ensure maximum operating (alarm) temperature switch is closed. ◆ Ensure low gas pressure switch are closed. ◆ See page 20 of the Riello catalogue for burner controller trouble shooting.
<ul style="list-style-type: none"> ◆ Unit does not start 	<ul style="list-style-type: none"> ◆ Blower does not run. ◆ Air pressure switch installed on the housing is open. ◆ Gas pressure switch is open. ◆ No ignition. 	<ul style="list-style-type: none"> ◆ See above ◆ Adjust switch. ◆ Replace switch (if defective). ◆ Adjust the switch. ◆ Replace switch (if defective). ◆ See page 20 of the Riello catalogue for burner trouble controller trouble shooting
<ul style="list-style-type: none"> ◆ Pilot flame failure 	<ul style="list-style-type: none"> ◆ Pilot gas valve not opened ◆ No ignition 	<ul style="list-style-type: none"> ◆ Check the electrical connections to ensure they are all securely connected (see the schematic wiring diagram for terminals). ◆ Check the two safety shut off valves. Replace if defective. ◆ Check the electrical connections to ensure they are all securely connected (see “Factory Wiring Diagram” on page 15 of the Riello catalogue) for terminals. ◆ Check the flame rod to ensure it is clean and free of any sedimentation. Clean flame rod if necessary. ◆ Check the flame rod for any cracks or other defects. Replace flame rod if necessary. ◆ Measure gas pressure in the pilot line at the exit test port of the second safety valve (downstream of the regulator). Ensure it is within the specified 2”-5” wc. If pressure is not available check both safety shut off valves and the pressure regulator. Replace any defective component, if necessary.
<ul style="list-style-type: none"> ◆ Main flame failure 	<ul style="list-style-type: none"> ◆ Main gas valve not opened. 	<ul style="list-style-type: none"> ◆ Check the electrical connections to ensure they

	<ul style="list-style-type: none"> ◆ Insufficient gas pressure ◆ Unit out of adjustment ◆ Insufficient draft 	<p>are all securely connected.</p> <ul style="list-style-type: none"> ◆ Check the two safety shut off valves. Replace if defective. ◆ Check gas pressure at the inlet test port of the first safety shut off valve. It should be within the specified 7-14" wc range. Adjust the pressure regulator to obtain the required pressure. If problem persists, replace the valve. Repeat process for the second safety shut off valve. ◆ Check the gas manifold pressure to ensure it complies with the value given in the factory test report. If required, re-adjust the boiler/water (see factory test report for the adjustment values). ◆ Check the vent system to ensure it is not clogged.
<ul style="list-style-type: none"> ◆ Unit fails at frequent intervals (excessive cycling) 	<ul style="list-style-type: none"> ◆ Maximum operating (alarm) temperature is set too low. ◆ Break in controls wiring. ◆ Unit is over-sized 	<ul style="list-style-type: none"> ◆ Check the setting on the maximum operating (alarm) temperature switch to ensure it is set at the maximum design temperature. ◆ If applicable, check the differential adjustment on the maximum operating temperature switch. ◆ Check all connections to and from the wiring block located immediately below the blower. ◆ Check the maximum heat requirement with the engineer and ensure the unit is of the appropriate size.
<ul style="list-style-type: none"> ◆ Unclean combustion 	<ul style="list-style-type: none"> ◆ Insufficient air in the mechanical room ◆ Unit out of adjustment 	<ul style="list-style-type: none"> ◆ Check all the louvers and air openings in the mechanical room to ensure they are free of any obstructions and there is sufficient inflow of fresh air into the room. ◆ Using a gas analyzer re-adjust the air and gas settings.
<ul style="list-style-type: none"> ◆ Air bubble sound in the unit. 	<ul style="list-style-type: none"> ◆ Poor water circulation in one or both coils ◆ Foreign material in one or both coils. ◆ Steam pockets in one or both coils. 	<ul style="list-style-type: none"> ◆ Completely purge each coil. ◆ Drain each coil with pressurized air and re-purge. ◆ Check water flow rate in each coil to ensure it complies with the required minimum flow rate (18 GPM).
<ul style="list-style-type: none"> ◆ Gas Odor 	<ul style="list-style-type: none"> ◆ Leak in piping. ◆ Exhaust gas leakage 	<ul style="list-style-type: none"> ◆ Using a gas detector, check all the connections (inlet and outlet) of all instruments on the gas line. Repair as required. ◆ Check the vent system to ensure there are no cracks or other openings (holes cut for insertion of thermocouples during the start-up). Repair if

		required.
--	--	-----------